



# Agilent Inline Pressure Relief Valve Kit

## Technical Note

This note describes the installation and use of the Inline Pressure Relief Valve into the

- Agilent 1290 Infinity Diode Array Detector (G4212A/B)
- Agilent 1200 Infinity II Series Diode Array Detector (G7117A/B/C)

When several detectors are installed in a system the connecting capillary and fittings between the detectors must be carefully chosen to keep chromatographic influence on peak shape small. On the other hand narrow bore connection capillaries generate a significant pressure drop dependent on flow rate and solvent properties.

The pressure relief valve is designed to protect the flow cell of a Diode Array Detector (G4212A/B and G7117A/B/C). It opens above 80 bar.

Agilent strongly recommends installing the pressure relief valve at the outlet of the detector as soon as a second detector is installed like in LC/MS applications.

## Contents

**General Information** 1

**Installation Procedure** 3

**Maintenance** 6

## General Information

### Delivery Checklist

Make sure all parts and materials have been delivered. Please report missing or damaged parts to your local Agilent Technologies sales and service office.

#### NOTE

All parts are not assembled.



**General Information**  
Information on Connecting Tubing

*Delivered Parts - Inline Pressure Relief Valve Kit (G4212-68001)*

Item #	p/n	Description
1	G4212-60022	Pressure Relief Valve
2	5022-2168	Fitting PK for 1/32" capillary
3	0100-1711	Male Nut PK 1/16" x 10-32
4	0890-2207	Tubing/Sleeving-Flex
5	0890-1915	Capillary PK 0.13 mm x 150 cm
6	5043-0266	Capillary FS/PK 125 µm x 71 mm
7	G4212-20040	Tube Connector (for G4212A/B only)
	G4212-90120	Technical Note

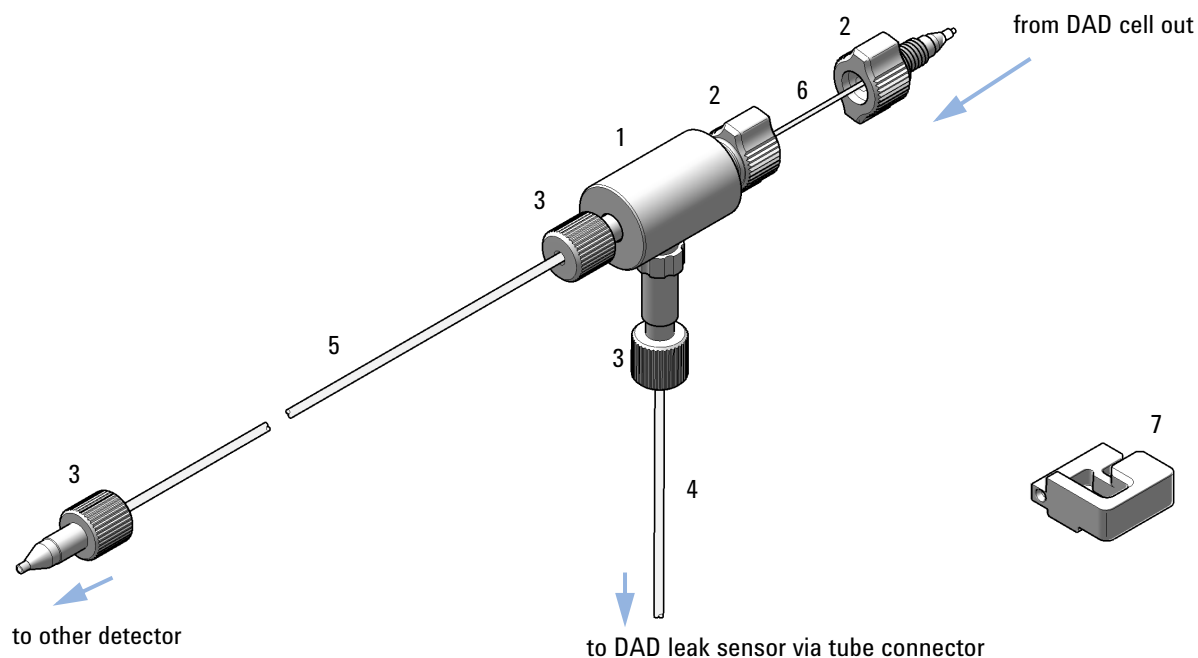

**Figure 1** Inline Pressure Relief Valve Kit (parts involved)

## Information on Connecting Tubing

**NOTE**

Capillary PK 0.13 mm x 150 cm (0890-1915) is adapted for flow rates up to 2.5 mL/min and capillary length below 400 mm.

For higher flow rates, connecting capillaries much longer than 400 mm or solvents with high viscosities (e.g. isopropanol) it's recommended to use Capillary PK 0.18 mm x 1.5 m (0890-1763).

# Installation Procedure

**NOTE**

There is no specific flow direction through the pressure relief valve. It can be connected in both directions.

## Connect tubings and capillaries

For details on parts, see [Figure 1](#) on page 2

- 1** Connect the inlet capillary (item 6) to the pressure relief valve (item 1). Use the PEEK fitting (item 3).

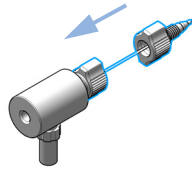

- 2** Connect the flexible tubing (item 4) to the pressure relief valve (item 1). Use a PEEK fitting (item 3).

**NOTE**

The PTFE tubing is 16 cm long and precut.

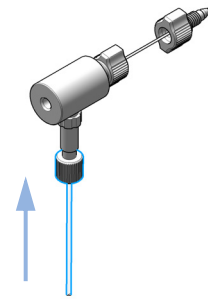

- 3** Determine the minimum length for the outlet connecting capillary (item 6). Cut the required length of the PEEK tubing (item 5).

**NOTE**

Use the Plastic tubing cutter (8710-1930). Keep the length as short as possible. Consider the length as described in [“Information on Connecting Tubing”](#) on page 2.

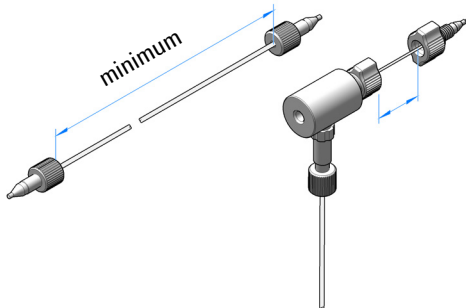

- 4** Connect the outlet capillary (item 5) to the pressure relief valve (item 1). Use the PEEK fitting (item 3). The completely assembled Pressure Relief Valve is shown below.

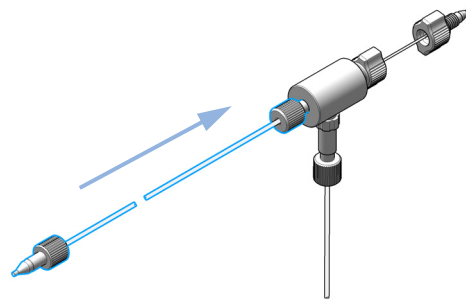

**5** Connect the short capillary (item 6) to the detector outlet. Use the PEEK fitting (item 2).

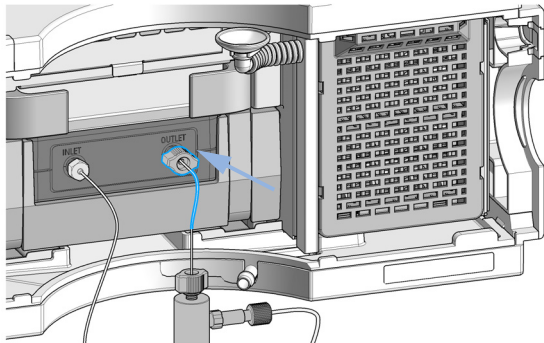

**Connect the pressure relief valve to G4212A/B**

**1** Unclip the waste funnel from the holder and slide the Leak downpipe up for removal.

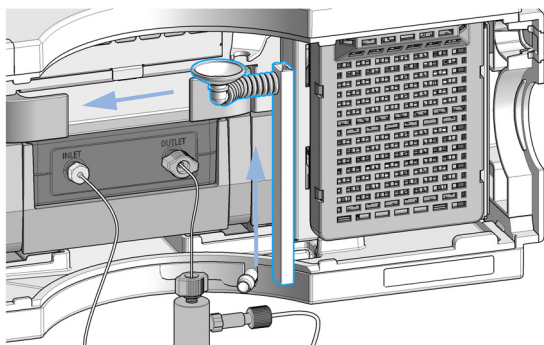

**2** Place the Tube Connector (item 7) close to the leak sensor area.

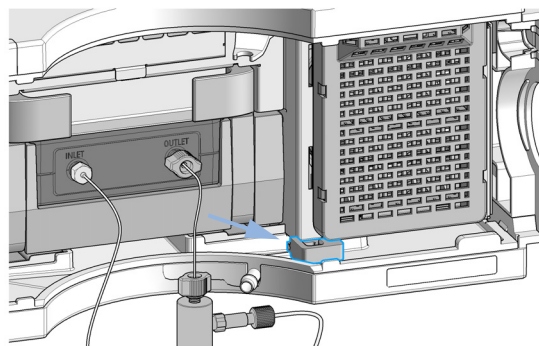

**3** Slide the Leak Down Pipe into its position and clip the waste funnel back into the holder.

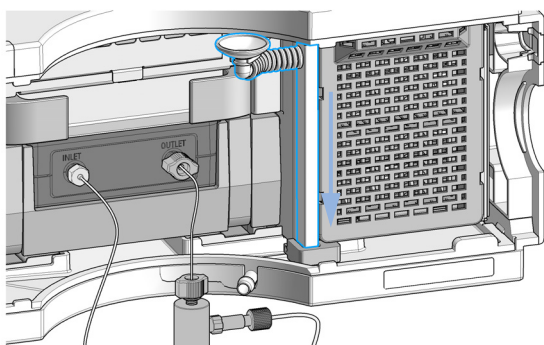

**4** Insert the waste tubing completely into the Tube Connector.

**NOTE**

Make sure the waste tube is correctly positioned to ensure reliable stop of flow in case of overpressure.

**NOTE**

To dry the area around the leak sensor in case of a leak, the Leak Down Pipe and Tube Connector have to be removed, see steps above.

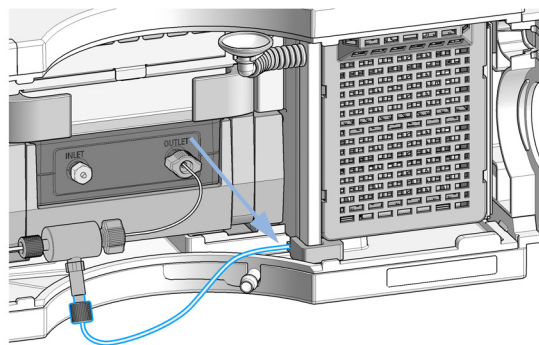

### Connect the pressure relief valve to G7117A/B/C

- 1 Route the waste tubing towards the leak sensor and fix its position with a tape.

#### NOTE

Make sure the waste tube is correctly positioned to ensure reliable stop of flow in case of overpressure.

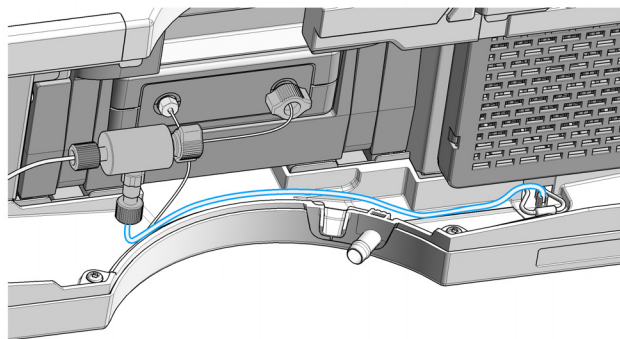

### Routing of the Outlet Capillary (G4212A/B, G7117A/B/C)

- 1 Route the outlet capillary (item 5) through the cover as shown below.

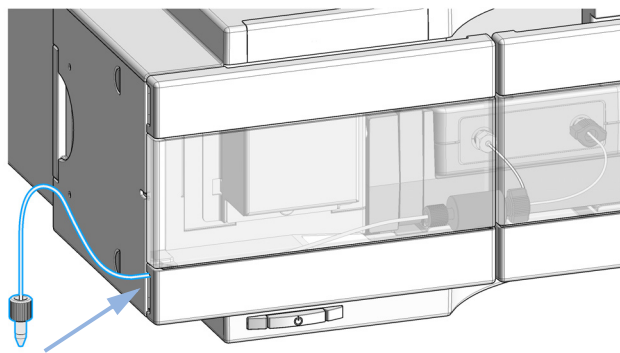

- 2 Connect the outlet capillary (item 5) to the second detector (for example MS). Use the PEEK fitting (item 3).

## Maintenance

### Cautions and Warnings

#### WARNING

**When opening capillary or tube fittings solvents may leak out.**

**The handling of toxic and hazardous solvents and reagents can hold health risks.**

→ Please observe appropriate safety procedures (for example, goggles, safety gloves and protective clothing) as described in the material handling and safety data sheet supplied by the solvent vendor, especially when toxic or hazardous solvents are used.

---

The pressure relief valve is a security valve. It limits the pressure onto the flow cell. Once the relief valve was activated it's recommended to follow the steps below to ensure reliable tightness again.

If this procedure does not tighten the Pressure Relief Valve, replace it.

### Clean the Pressure Relief Valve

- 1 Disconnect the inlet, outlet capillary and the waste tube from the Pressure Relief Valve.
- 2 Use a beaker with isopropanol (must be absolutely clean).
- 3 Put the Pressure Relief Valve into the beaker.
- 4 Ultrasonic the Pressure Relief Valve for 2 min.
- 5 Remove the Pressure Relief Valve.

## Pressurize the Pressure Relieve Valve Outlet

**Preparations** Use water for the procedure.

**NOTE**

This procedure must be done outside of the detector.

- 1 Connect the HPLC- pump outlet capillary to the waste outlet of the Pressure Relief Valve.
- 2 Set the maximum pressure of the pump to 300 bar.
- 3 Set flow rate to 0.1 mL/min and select channel with aqueous solvent.
- 4 Switch the pump on and pressurize the Pressure Relief Valve until the pump is stopped by overpressure.
- 5 Keep the pressure for approximately 1 min onto the Pressure Relief Valve.
- 6 Set the flow rate to 0 mL/min.
- 7 Turn off the pump.
- 8 Open the manual purge valve (if installed in the pump).

OR

If no manual purge valve is available carefully open the capillary from the waste port of the Pressure Relief Valve.

**NOTE**

This will release a small amount of solvent.

Pressure is released.

## Reinstall the Pressure Relief Valve

- 1 Reconnect the capillaries (inlet and outlet).
- 2 Reconnect the waste tube.
- 3 Reconnect the waste tube end in the tube connector (connector above the leak sensor in the detector).

**NOTE**

Make sure the waste tube is correctly positioned to ensure reliable stop of flow in case of overpressure, see "[Installation Procedure](#)" on page 3.

## Correcting Leaks

**When** In case of a leak.

**Preparations** System is turned off.

- 1 Remove the Leak Down Pipe and Tube Connector, see [“Installation Procedure”](#) on page 3.
- 2 Dry the area around the leak sensor.



G4212-90120

Part Number: G4212-90120 Rev. B

Edition: 03/2016  
Printed in Germany

© Agilent Technologies, Inc 2016

Agilent Technologies, Inc  
Hewlett-Packard-Strasse 8  
76337 Waldbronn  
Germany