

# Agilent Splitter Kits

## Installation and Configuration

This technical note describes the installation and configuration of the Agilent Splitter Kits in an Agilent 1260 Infinity Series System or an Agilent 218/SD-1 Purification System with an Agilent 1260 Infinity ELSD detector (G4260A/B).

### Contents

**Intended Use of the Splitter Kits 2**

**Delivery Checklist 3**

**Physical Layout 4**

**Additional Required Modules and Parts 5**

**Specifications 5**

**Installation 6**

Installing the Splitter Kits for 1-5 mL/min (5023-2255) and 2-10 mL/min (5023-2256) 6

Installing the Splitter Kits 8–40 mL/min (5023-2257) and 25–100 mL/min(5023-2258) 6

Installing the Splitter Kits for 75-300 mL/min (5023-2259) 7

**Configuration of the Agilent System With an ELSD 8**

Configuration On an Agilent 1200 Series Purification System 8

Configuration On an Agilent 218/SD-1 Purification System 9

**Operation – Use with an ELSD Detector 10**

**Troubleshooting 11**

No ELSD and UIB/CIM signal 11

No UIB/CIM signal but ELSD signal 11



## Intended Use of the Splitter Kits

The splitter kits are designed for preparative HPLC applications with flow from 1 mL/min to 300 mL/min to split the preparative flow after UV detection between the Fraction Collector (FC) and an ELSD. The split is achieved by flow restrictions that are generated by the system backpressure after the column and UV-detection. Thus, for different flow rate ranges and systems, different splitter kits are required. The following figure gives an overview of the different splitter configurations depending on purification scales and systems.



**Figure 1** Splitter and capillary kits available for the different flow rate ranges and purification systems

## Delivery Checklist

Different kits correspond to different flow rate ranges, as described below.

	<b>Description</b>
5023-2255	Splitter kit 1 – 5 mL/min
5023-2256	Splitter kit 2 – 10 mL/min
5023-2257	Splitter kit 8 – 40 mL/min
5023-2258	Splitter kit 25 – 100 mL/min
5023-2259	Splitter kit 75 – 300 mL/min

Each kit is delivered with:

- Capillary to Fraction Collector Analytical Scale (FC-AS) or Capillary to Fraction Collector (FC), part number depending on the splitter kit
- Capillary to ELSD, part number depending on the splitter kit
- High Flow union, ST, no fitting (5022-2133)
- T-connector, PEEK, 1/16 in, 0.57  $\mu$ L swept volume (5022-2144)
- Colored finger-tight PEEK fittings, 10/PK (5065-4426)

and an additional delay coil for flow rate ranges above 25 mL/min:

- Tube PTFE 0.7 mm x 5 m, 1.6 mm od (5062-2462), for kits 5023-2257 and 5023-2258
- Tube PTFE 1.5 mm x 5 m, 3 mm od (5062-2483), coupled with the PEEK adapter 1/4-28 female to 10-32 male (UCP652), for kit 5023-2259

## Physical Layout

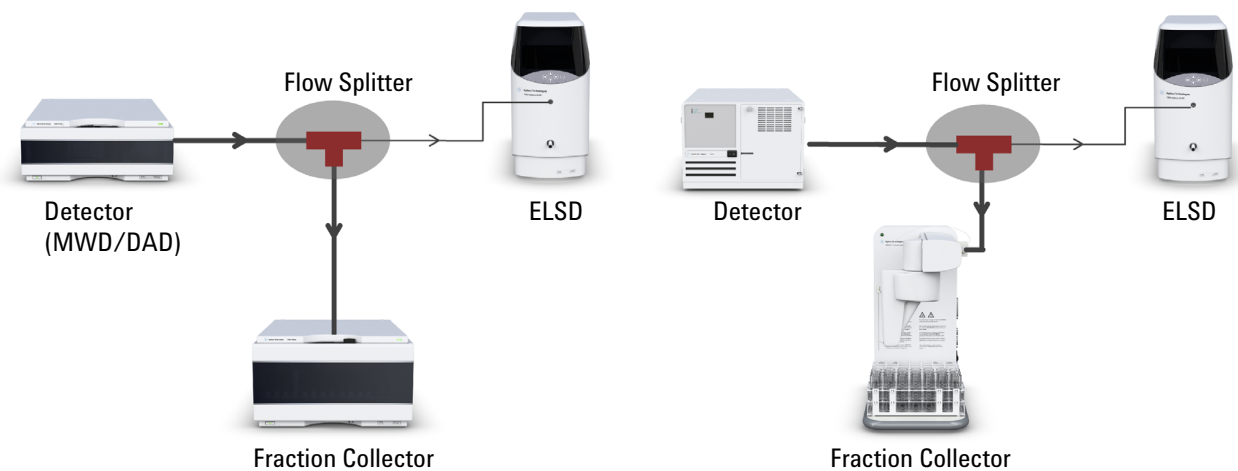

**Figure 2** Schematic view of the splitter configurations on the Agilent 1260 Infinity system (left) and 218/SD-1 Purification system (right)

## Additional Required Modules and Parts

**Table 1** Required modules and parts

<b>Agilent 1200 Series System</b>	<b>Agilent 218/SD-1 Purification System</b>
G4260A/B	G4260A/B
Analog Output Cable (PL0880-0310) for G4260B or Analog Output Cable (PL0890-0300) for G4260A	Analog Output Cable (PL0880-0310) for G4260B or Analog Output Cable (PL0890-0300) for G4260A
G1390B with options #62 (Cable Analog Out (BNC) to BNC) and #68 (Quick connect adapter for open end cable)	Remote Start Cable (PL0860-0055) for Third Party LCs (218/SD-1)
	Assy USB RS232 serial adaptor MS WHQL (7910062900)

## Specifications

**Table 2** Specifications

<b>Type</b>	<b>Specification</b>
Operating preparative flow rates	Depending of the splitter kits, see <a href="#">Figure 1</a> on page 2
Resulting split flow	0.1 – 1.5 mL/min
Working pressure	Up to 200 bar
Material	PEEK

## Installation

Installing the Splitter Kits for 1-5 mL/min (5023-2255) and 2-10 mL/min (5023-2256)

## Installation

### Installing the Splitter Kits for 1-5 mL/min (5023-2255) and 2-10 mL/min (5023-2256)

- 1 Connect the PEEK capillary delivered with the Agilent system from UV detector to the T-connector as described on the scheme below.
- 2 Connect the “Capillary To ELSD” from the T-connector to the ELSD.
- 3 Connect the “Capillary To FC” or “Capillary To FC-AS” from the T-connector to the Fraction collector.

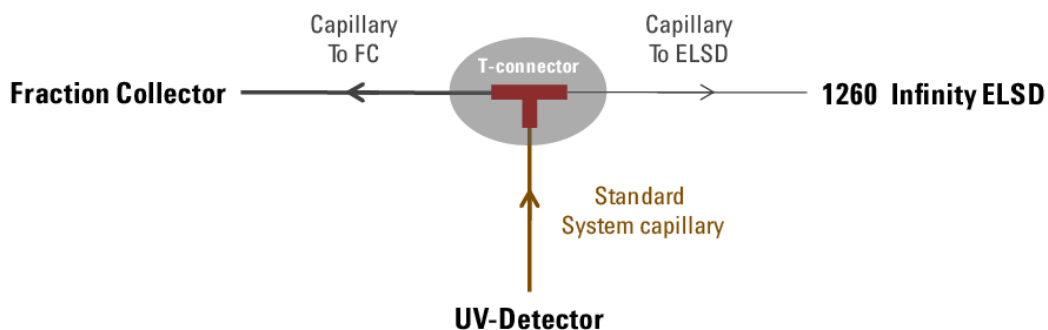

Figure 3 Installation of the Splitter Kits 1-5 ml/min and 2-10 ml/min

### Installing the Splitter Kits 8–40 mL/min (5023-2257) and 25–100 mL/min (5023-2258)

- 1 Connect the PEEK capillary delivered with the Agilent system from UV detector to the T-connector as shown below.
- 2 Connect the “Capillary To ELSD” from the T-connector to the ELSD.
- 3 Connect the “Capillary To FC” from the T-connector to the delay coil using a high flow union.
- 4 Connect the second extremity of the delay coil to the fraction collector.

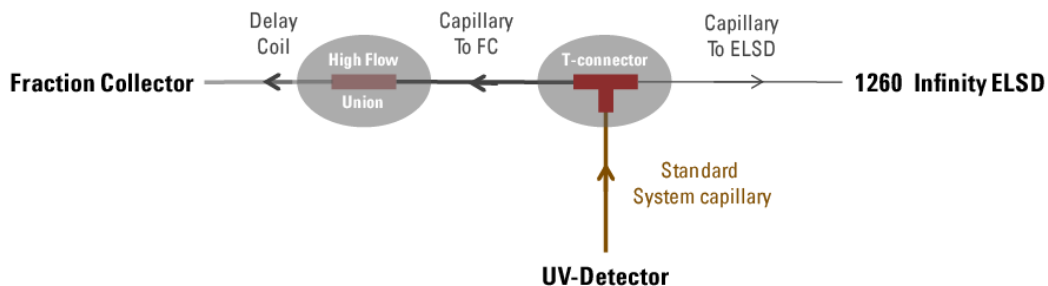
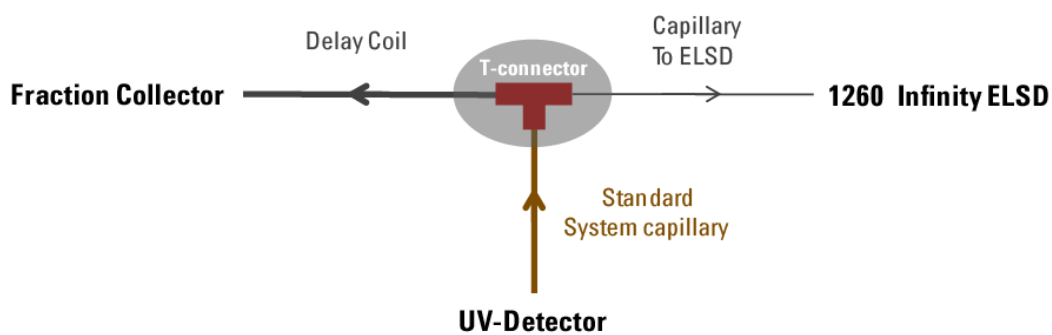

Figure 4 Installation of the Splitter Kits 8 – 40 mL/min and 25 – 100 mL/min

## Installing the Splitter Kits for 75-300 mL/min (5023-2259)

- 1 Connect the PEEK capillary delivered with the Agilent system from UV detector to the T-connector as described on the scheme below.
- 2 Connect the “Capillary To ELSD” from the T-connector to the ELSD.
- 3 Connect the delay coil (Tube PTFE 1.5 mm x 5 m, 3 mm od (5062-2483)) from the T-connector using an adapter PEEK, 1/4-28 female to 10-32 male, to the fraction collector.



**Figure 5** Installation of the Splitter Kit 75 – 300 mL/min

# Configuration of the Agilent System With an ELSD

## Configuration On an Agilent 1200 Series Purification System

### System Overview



**Figure 6** Configuration of a 1260 Infinity Series Purification System with ELSD

### Cable Connections

**Table 3** Cable connections for a 1260 Infinity Series Purification System with ELSD

Cable	Connection	Comment
RS232 communication cable (PL0890-0325)	RS232 port of ELSD to serial port of instrument PC	delivered with ELSD
Remote start cable (third party LCs only) (PL0890-0350)	Remote port of UV detector to AUX 0/I of ELSD	delivered with ELSD
Analog Output Cable (PL0890-0300) or Analog Output Cable (PL0880-0310)	ELSD output port to the BNC to general purpose cable G1390#062 with a quick connect adapter G1390#068 from UIB II	for G4260A ELSD for G4260B ELSD

### Delay Calibration

The delay calibration is performed with the Agilent Lab Advisor Software. See the Fraction collector User Manual or Lab Advisor User Manual for details.



## Configuration On an Agilent 218/SD-1 Purification System

### System Overview



**Figure 7** Configuration of a 218/SD-1 Purification System with ELSD

### Cable Connections

**Table 4** Cable connections for a 218/SD-1 Purification System with ELSD

Cable	Connection	Comment
RS232 communication cable (PL0890-0325)	RS232 port of ELSD to serial port of instrument PC	delivered with ELSD
Remote Start Cable (PL0860-0055)	Relay 1 from the 218/SD-1 pump CIM and AUX 0/I from the ELSD.	for third party LCs (option of the ELSD)
Analog Output Cable (PL0890-0300) or Analog Output Cable (PL0880-0310)	ELSD output port to the 218/SD-1 CIM INTGR HI/LO ports.	for G4260A ELSD  for G4260B ELSD

### Delay Calibration

The delay calibration is performed with a counter watch. See the Agilent 440-LC Fraction Collector User Manual for details.

## **Operation – Use with an ELSD Detector**

For complex mixtures, natural products, small molecules, or low-UV-wavelengths absorbing compounds, the use of an ELSD is a perfect solution to achieve reliable sample purification. In addition, this detection method allows adjustments of the different detector parameters like light intensity, nebulizer temperature, gas flow, and temperature. This flexibility enhances the detector capabilities toward preparative specific application.

As an example, in preparative liquid chromatography, the sensitivity of the detection method is an important criteria. By reducing or increasing the light intensity of the ELSD, the sensitivity of the detector can be adjusted to the concentration used for the sample purification. Nevertheless, for high concentration, this detector being highly sensitive, saturation of the detector can be observed even with a low light intensity. In this particular case, to perform fine purification results, the fraction collector settings can be modified.

For the 1260 Infinity Fraction Collector, the upper threshold can be set below the detector saturation such as 1500 mV for a standard Analog Output signal. For the 440-LC Fraction Collector, slope triggering can be disabled.

## Troubleshooting

### No ELSD and UIB/CIM signal

#### Probable cause

- 1 UV-signal but no ELSD and UIB/CIM signal can be observed
- 2 No UV signal can be observed

#### Suggested actions

- Replace splitter kit capillary "Capillary to ELSD".
- Refer to user manual of the Agilent preparative system.

### No UIB/CIM signal but ELSD signal

#### Probable cause

- 1 No UIB/CIM signal but ELSD signal can be observed

#### Suggested actions

- Shutdown all system modules and check the fine electrical connection of the Analog Output Cable to the CIM or UIB port.
- If an UIB is used, check the CAN cable connecting the UIB to the Agilent system.

**Troubleshooting**

No UIB/CIM signal but ELSD signal



5974-0158

Part Number: 5974-0158

Edition: 02/2014  
Printed in Germany

© Agilent Technologies, Inc 2014

Agilent Technologies, Inc  
Hewlett-Packard-Strasse 8  
76337 Waldbronn  
Germany